

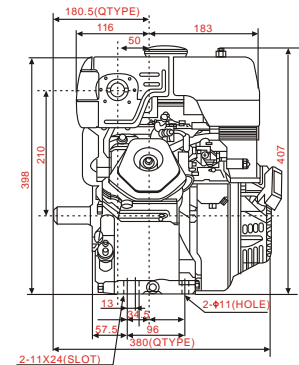

# ESE240/ESE270 SERIES GASOLINE ENGINE

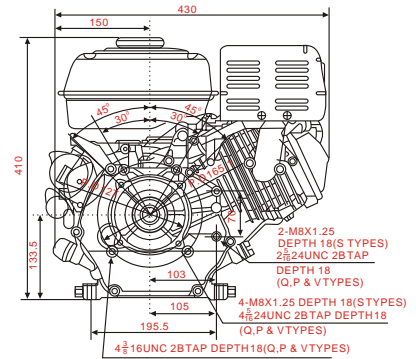

Performance curve		
Max. Power output	Recommended rotate speed(rpm)	
Recommended Operating power	Recommended rotate speed(rpm)	
Max. Torque	Recommended rotate speed(rpm)	
<b>Specifications</b>	<b>ESE240</b>	<b>ESE270</b>
Type	ESE40C	
Model	Air-cooled 4 stroke OHV single cylinder	
Engine type	73mmX58mm	77mmX58mm
Bore X Stroke	242ml	
Displacement	8.2:1	
Compression ratio	8HP/3600rpm	9HP/3600rpm
Max. Power output	16.7N.m/2500rpm	19.1N.m/2500rpm
Max. Torque	Non-contact transistorized ignition(TCL)	
Ignition system	Recoil and hand-operated	
Start mode	Semi-dry,oil bath,dual, double silentand cyclone type	
Air cleaner	6L	
Fuel tank capacity	290g/HP-hour	
Fuel consumption	1.1L	
Engine oil capacity	440mmX365mmX465mm	
Dimension(LXWXH)	28kg	
Gross weight	272pcs	
20°FCL		

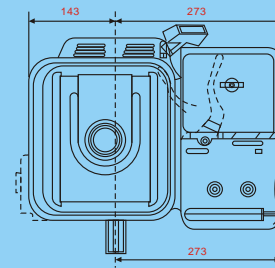